



Connection Impact Assessment (CIA) Application

GSHi Engineering Dept | DERconnections@gsuinc.ca | 705-675-7536



Validate Form
Clear Form

▶ ABOUT THIS FORM

This Connection Impact Assessment (CIA) application is to be completed by any proponent interested in connecting a Distributed Energy Resources (DER) with a project size over 10 kilowatts (kW) to Greater Sudbury Hydro Inc. ("GSHi"). This includes DER applying for a new CIA or for revision(s) to their original CIA. This form expresses an intent to enter into an agreement between GSHi and the customer (or host customer* for load displacement projects) for completion of a CIA associated with connecting a DER to GSHi distribution grid. The CIA Application shall be part of the required servicing (electrical installation, maintenance, and operating) agreements between GSHi and the proponent. Through this process, GSHi will be the proponent's contact with the transmission system provider (e.g. Hydro One Networks Inc.) and, if necessary, the provincial market operator, namely, the Independent Electricity System Operator (IESO).

*For Load Displacement projects, the term "host customer" refers to the owner of the load facility. The term "DER owner" refers to the owner of the DER facility.

▶ TECHNICAL REQUIREMENTS

For technical requirements of GSHi's DER projects, refer to the "DER Technical Interconnection Requirements Interconnections at Voltages 50kV and Below", available at:

[DISTRIBUTED GENERATION TECHNICAL INTERCONNECTION REQUIREMENTS](#)

▶ SUBMISSION INSTRUCTIONS

Please return the completed form, fees and other required documents by mail to:

Greater Sudbury Hydro Inc.

Attn: Engineering Department
Generation Connection Application
500 Regent St, Sudbury, ON P3E 3Y2
DERconnections@gsuinc.ca

▶ IMPORTANT NOTES

- An engineering stamp and all red box fields (on electronic version of form) are mandatory. Incomplete applications may be returned by GSHi and will result in delays in processing your application. Click the "Validate Form" button on the top right of this page to ensure all required information is filled. If any of the required fields are not applicable to your project, type "N/A" in any required text field or "0" in any required numerical field
- GSHi specific requirements and notes are found in Sections S and T, respectively
- Applicants are cautioned NOT to incur major expenses until GSHi approves to connect the proposed DER facility.
- All technical submissions (CIA Application, Single Line Diagrams, etc.) must be signed, dated and sealed by a licensed Ontario Professional Engineer (P.Eng.).
- The proponent will pay for the CIA according to GSHi's CIA Fee Schedule.





- The siting restrictions in O. Reg. 274/18 which were administered by electricity distributors such as GSHi have been replaced by amendments to the Planning Act (Ontario) that puts siting and planning requirements for renewable DER facilities under municipal oversight. It is recommended that you discuss municipal permitting and approvals requirements with the planning department in the municipality where your DER project is located before you proceed.

▶ SECTION A: APPLICATION INFORMATION

Engineering Stamp	Application Type <i>choose one</i>	Date <i>mm/dd/yyyy</i>
	New CIA Application	11/23/2021
	Program Type/Purpose <i>choose one</i>	Program Type (additional details)
	Load Displacement	
	Project Name	BEHIND THE METER EXAMPLE
IESO Contract Number <i>F-XXXXXX-XXXX-XXXX-XXXX</i>	IESO Reference Number <i>FIT-XXXXXXX</i>	
Ontario Corporate Number or Business Identification Number	Proposed In Service Date <i>mm/dd/yyyy</i>	
2021012	01/05/2022	
<i>If this project is a subdivision project, please complete the following fields:</i>		
Subdivision Project Name	Number of Lots	
<i>For certain application type selections, please complete the required fields:</i>		
Original CIA Project ID # <i>xx,xxx</i>		
Revised Fields <i>list the fields that have changed from your previous application</i>		

▶ SECTION B: PROJECT LOCATION

Address	
Project Address Line 1	
City / Town / Township	Postal Code
City	A9A 9B9
Lot Number(s)	Concession Number(s)
01	2



▶ SECTION C: CONTACT INFORMATION

CIA will be issued in the name of the host customer (load facility owner). All agreements (including CCA and DCA) are only made between GSHi and the host customer. This section is strictly to gather contact information of some of the key contacts that are involved with the project.

Who is the single point of contact for this project?

- Host Customer
- DER Owner (if different from host customer)
- Consultant

Please enter the following information about the **host customer** (load facility owner)

Contact Person	Company's Legal Name
<input type="text" value="Name"/>	<input type="text" value="ABC Inc."/>
Mailing Address <small>including postal code, P.O. Boxes and Rural Routes will not be accepted</small>	
<input type="text" value="Address Line 1"/>	
Work Telephone	Cell Phone
<input type="text" value="(905) 500-7000"/>	<input type="text" value="(905) 500-3000"/>
Fax Number	Email Address
<input type="text" value="(905) 500-7001"/>	<input type="text" value="HostCustomer@example.com"/>

Please enter the following information about the **DER owner** (if different from host customer)

Contact Person	Company's Legal Name
<input type="text" value="Name"/>	<input type="text" value="ABC-C Inc."/>
Mailing Address <small>including postal code, P.O. Boxes and Rural Routes will not be accepted</small>	
<input type="text" value="Address Line 2"/>	
Work Telephone	Cell Phone
<input type="text" value="(905) 123-3000"/>	<input type="text" value="(905) 123-3002"/>
Fax Number	Email Address
<input type="text" value="(905) 123-3001"/>	<input type="text" value="DERowner@example.com"/>

Please enter the following information about the **consultant**

Contact Person	Company's Legal Name
<input type="text" value="Name"/>	<input type="text" value="Consultant Inc."/>
Mailing Address <small>including postal code, P.O. Boxes and Rural Routes will not be accepted</small>	
<input type="text" value="Address Line 3"/>	
Work Telephone	Cell Phone
<input type="text" value="(905) 123-4000"/>	<input type="text" value="(905) 123-4002"/>
Fax Number	Email Address
<input type="text" value="(905) 123-4001"/>	<input type="text" value="Consultant@example.com"/>





▶ SECTION D: CUSTOMER STATUS

Is there an existing GSHi account at the project location?

Yes No

Is the account holder aware of this application?

Yes No

Does your account fall within a residential-rate classification?

Yes No Do not Know

Existing Account Number

12345-12345

Account Holder Name

ABC Inc.

Does the account holder have an HST registration number?

Yes No

HST Number

1234567890

▶ SECTION E: EXISTING DER

Are there existing DER at the point of common coupling (PCC)?

Yes No

Existing Project Number

11,110

Existing Project Size (kW)

500.00

Program Type For Existing DER *choose one*

Net Metering

DER type: Synchronous Induction Inverter based Other

For synchronous units	For induction units	For inverter based units
Min. power limit for stable operation <i>kW</i> <input type="text"/>	Direct axis sub-transient reactance, X''_d <i>pu</i> <input type="text"/>	Inverter rating <i>kVA</i> <input type="text" value="500.000"/>
Direct axis sub-transient reactance, X''_d <i>pu</i> <input type="text"/>	Direct axis transient reactance, X'_d <i>pu</i> <input type="text"/>	Maximum continuous power output <i>kW</i> <input type="text" value="500.000"/>
Direct axis transient reactance, X'_d <i>pu</i> <input type="text"/>	Total PF correction installed <i>kVAR</i> <input type="text"/>	
Direct axis synchronous reactance, X_d <i>pu</i> <input type="text"/>		
Zero sequence reactance, X_0 <i>pu</i> <input type="text"/>		



▶ SECTION F: PROJECT INFORMATION

Station Name *(optional to leave blank for behind the meter projects)*

Example TS

Feeder *(optional to leave blank for behind the meter projects)*

M1

Feeder Voltage (kV) *(optional to leave blank for behind the meter projects)*

44.000

Project Size (kW) *total maximum output capacity*

3,000.00

Equipment Capacity (kVA) *total equipment nameplate rating*

3,000.00

Type of Connection

- Single Phase
- Three Phase

If this is a solar project, please answer the following questions:

Mounting Type *select one*

If this is a water project, please answer the following questions:

Is your generation facility located on provincial Crown or federally-regulated lands?

- Yes
- No

Is water your primary energy source?

- Yes
- No

Fuel/Energy Type *select all that apply*

- Solar (PV)
- Wind
- Water
- Natural Gas
- Biogas
- Biomass
- Diesel
- Battery Energy Storage System
- UPS
- CHP/Co-gen
- Other (specify below)

▶ SECTION G: STATION SERVICE LOAD INFORMATION

The host customer's station service load details

If there is an existing account at the project location, populating the fields in Section G is required for GSHi. Ensure selection below matches with this note.

- Required
- Optional

Maximum Demand of Station Service Load of DER *kW*

Average Monthly Consumption *kWh*



▶ SECTION H: CONNECTION INFORMATION

On a cut-out from GSHi DOM (Distribution Operating Map), or a site plan if a DOM is not made available by the LDC, provide the location of the generation facility with proposed line routings for connection to GSHi's distribution system. It should identify the Point of Expansion (POE), the Point of Common Coupling (PCC), the location of the generation facility, and (if applicable) the route of the new line between the generation facility and the POE (i.e.. on private property or public road/right-of-way). This is not required for existing load customers that are connecting a load displacement generation, net metering generation or energy storage system behind their existing metered connection point. Please see "Appendix A" for a visual representation of POE and PCC.

DOM Drawing/Sketch Number

DOM Revision Number

Please provide an SLD of the Generator's facilities, including the PCC, transformer and connecting station, feeder, and supply voltage.

SLD Drawing/Sketch Number

SLD Revision Number

POE Latitude degree decimal format

POE Longitude degree decimal format

PCC Latitude degree decimal format

PCC Longitude degree decimal format

Generation Facility Latitude degree decimal format

Generation Facility Longitude degree decimal format

Length of Line from POE to PCC km

Length of Line from PCC to Generation Facility km

Important: The line between the PCC and the Generation Facility must NOT be shared with any other DER owner (refer to Appendix A).

Conductor Type/Size for the line between the PCC and the Generation Facility

Generator Fault Contribution with fault location at the PCC

IMPORTANT NOTES:

If this project requires line expansion work between the POE and PCC, GSHi will provide a cost estimate to construct any line located on public road right-of-way. The cost estimate will include a breakdown of uncontestable work (i.e. overbuild to existing line) that can only be performed by GSHi, as well as contestable work (i.e. new construction/green-field) that may be performed by the Generator, their contractor or GSHi. The design of uncontestable and contestable work shall conform to GSHi specifications).

For Generator-owned line, the Generator may apply to construct the line on existing GSHi owned poles. This is known as an application for Joint Use (JU) of poles. If the application is accepted, GSHi will provide the Generator with information on initial connection costs, annual pole-space rental and emergency service (ES) fees and required JU & ES Agreements.





▶ SECTION I: ENERGY STORAGE OR UPS

Please complete the following section if your project includes energy storage.

Number of Units

Inverter Unit Size *enter zero if inverter is shared with generation unit(s)*

Energy Storage Unit Size *kWh*

Total Energy Storage Size *kWh*

Energy Storage Facility Control Strategy

- Peak Shaving
- Dynamic VAR Support
- Frequency Support
- Other

Please submit a detailed description of the control strategy according to the templates in Appendix B. GSHi reserves the right to modify the control strategy as part of its Detailed Technical Connection Assessment.

▶ SECTION J: LOAD DISPLACEMENT/PEAK SHAVING

Please complete the following section if this is a load displacement or peak shaving project

Operating Mode

- Parallel
- Non-Parallel

Transition Type

- Closed *"make before break"*
- Open *"break before make"*

Time that generator remains parallel to grid *closed transition only, ms*

For non-parallel load displacement, SCADA monitoring and Gross Load Billing (GLB) may apply. For load displacement generation facilities, please attach a schedule of the forecasted maximum generation output (as a function of loading of the facility). At a minimum, include the forecasted generation output information (i.e. Watts and VARs) during the minimum and maximum of the load facility to which the load displacement generator is connecting (see Appendix C for template)



SECTION K: DER CHARACTERISTICS (1/6)

For facilities with multiple generators: If your generators have different characteristics, please use the "Add Page" button and provide the characteristics for each generator on the additional pages.

DER type: Synchronous Induction Inverter based Other

Number of Generating Units: Rated Capacity of Each Unit: kW kVA DER Output Voltage *in kV*:

Manufacturer: Type or Model Number:

If Power Conversion Type is "Other", please provide values equivalent to a Synchronous or Induction type generator.

Maximum Starting In-rush Current *multiple of full load current, pu*: Generator Winding Connection: Delta Star

Neutral Grounding Method *for star winding connection only*: Solid Ungrounded Impedance Impedance R *in ohms*: Impedance X *in ohms*:

Limits of range of reactive power at the machine output:

Lagging *over-excited, kVAR*: Lagging Power Factor: Leading *under-excited, kVAR*: Leading Power Factor:

Limits of range of reactive power at the PCC:

Lagging *over-excited, kVAR*: Lagging Power Factor: Leading *under-excited, kVAR*: Leading Power Factor:

For synchronous units	For induction units
Nominal Machine Voltage <i>kV (LL)</i> <input type="text"/>	Nominal Machine Voltage <i>kV (LL)</i> <input type="text"/>
Unsaturated Reactance <i>kVA Base</i> <input type="text"/>	Unsaturated Reactance <i>kVA Base</i> <input type="text"/>
Unsaturated Reactance <i>kV Base</i> <input type="text"/>	Unsaturated Reactance <i>kV Base</i> <input type="text"/>
Direct Axis Subtransient Reactance, $X_{d''}$ <i>pu</i> <input type="text"/>	Direct Axis Subtransient Reactance, $X_{d''}$ <i>pu</i> <input type="text"/>
Direct Axis Transient Reactance, $X_{d'}$ <i>pu</i> <input type="text"/>	
Direct Axis Synchronous Reactance, X_d <i>pu</i> <input type="text"/>	
Subtransient Time, $T_{d''}$ <i>ms</i> <input type="text"/>	
Zero Sequence Reactance, X_0 <i>pu</i> <input type="text"/>	

Add Page





SAMPLE



SECTION L: INTERFACE TRANSFORMER

The transformer connecting to the GSHi distribution system

Transformer Ownership

- Customer GSHi

Transformer Rating *KVA*

3,000.00

Transformer Type

- Single Phase Three Phase

Nominal Voltage of High Voltage Winding *kV*

44.000

Nominal Voltage of Low Voltage Winding *kV*

0.600

Impedance Base (if different than ratings above)

kVA Base

kV Base

Impedance (R) *pu*

Impedance (X) *pu*

OR

Impedance (Z%) %

6.00

High Voltage Winding Connection

- Delta Star

High Voltage Grounding Method *for star winding connection only*

- Solid Ungrounded Impedance

Star Impedance R *in ohms*

Star Impedance X *in ohms*

Low Voltage Winding Connection

- Delta Star

Low Voltage Grounding Method *for star winding connection only*

- Solid Ungrounded Impedance

Star Impedance R *in ohms*

Star Impedance X *in ohms*

Notes

The term "High Voltage" refers to the connection voltage to GSHi's distribution system and "Low Voltage" refers to the generation or any other intermediate voltage.

Providing a photo of transformer equipment along with this application may help expedite your application.



SECTION M: INTERMEDIATE TRANSFORMER

Transformer between the interface transformer and DER

Please complete the following section if your project includes an intermediate transformer.

Do you intend to install an intermediate transformer?

- Yes No

Transformer Rating kVA

Transformer Type

- Single Phase Three Phase

Nominal Voltage of High Voltage Winding kV

Nominal Voltage of Low Voltage Winding kV

Impedance

kVA Base

kV Base

Impedance R pu

Impedance X pu

High Voltage Winding Connection

- Delta Star

High Voltage Grounding Method for star winding connection only

- Solid Ungrounded Impedance

Star Impedance R in ohms

Star Impedance X in ohms

Low Voltage Winding Connection

- Delta Star

Low Voltage Grounding Method for star winding connection only

- Solid Ungrounded Impedance

Star Impedance R in ohms

Star Impedance X in ohms

Notes:

The term "High Voltage" refers to the connection voltage to GSHi's distribution system and "Low Voltage" refers to the generation or any other intermediate voltage.

SECTION N: HIGH-VOLTAGE GROUNDING TRANSFORMER

Please complete the following section if your project includes a high-voltage grounding transformer.

Do you have a high-voltage grounding transformer?

- Yes No

Transformer Type select one

- Zig-Zag Star-Delta

Zero Sequence Impedance (Z0) R ohms

Zero Sequence Impedance (Z0) X ohms



▶ SECTION O: SUBMISSION CHECKLIST

Please ensure the following items are completed prior to submission. Your application may not be processed if any part is omitted or incomplete:

- Payment in full including applicable taxes (by cheque payable to "Greater Sudbury Hydro Inc")
- Completed Form B stamped by a Professional Engineer
- Signed Study Agreement (original signature is required)
- Single Line Diagram (SLD) of the Generator's facilities, must be stamped by a Professional Engineer
- Protection Philosophy
- Distribution Operating Map (DOM) and/or Site Plan (not required for existing load customers that are connecting a load displacement generation, net metering generation or energy storage system behind their existing metered connection point)
- Load Displacement Generation Facility's load and generation schedules (if applicable)
- Load Displacement Generation Facility's mode of operation (if applicable)
- Energy Storage Facility operating strategy description an parameters (if applicable)
- Emergency Backup Generation Facility's mode of operation (if applicable)

▶ SECTION P: CIA APPLICATION FEE CHECKLIST

Please ensure the following items are completed prior to submission. Your application will not be processed if any part is omitted or incomplete. Check all that apply:

- Applicable CIA Fee**
See the Connection Impact Assessment Fee Schedule on our website for costs. Please enter the amount from the fee schedule. \$ +HST
- Transmission Customer Impact Assessment (TxCIA) Fee (if applicable)**
A TxCIA is also required if the total nameplate generation of the project is greater than 10MW. \$ +HST
- IESO System Impact Assessment (SIA) Fee (if applicable)**
An SIA deposit is required if the total nameplate generation of the project is greater than 10MW. The total cost of the SIA will be Trued Up/Down upon the receipt of the SIA from the IESO. See the IESO's SIA Application for costs. \$



SECTION Q: ATTACHMENTS

Attached Documents / Drawings

Item #	Description	Document #	# of Pages
1	Single Line Diagram	1	1
2	Protection Philosophy	1	5
3	Inverter Certification [Not Shown in Sample CIA Application Package]	1	1
4			
5			
6			

SECTION R: NOTES

SAMPLE



▶ SECTION S: GSHi Specific Required Fields

This section contains specific information that is required by GSHi. Please read Section T notes regarding this section if you need further details.

What is the barcode of the nearest pole serving the project location?

GSHi Account Number *if transformer is owned by GSHi*

▶ SECTION T: GSHi Specific Additional Notes

Section A: no additional notes

Section B: no additional notes

Section C: no additional notes

Section D: no additional notes

Section E: no additional notes

Section F: no additional notes

Section G: no additional notes

Section H: no additional notes

Section I: no additional notes

Section J: no additional notes

Section K: no additional notes

Section L: At the Generator's expense, and if requested, GSHi may provide transformation up to the relevant limit as per the current version of Hydro One's Technical Interconnection Requirements.

Section M: no additional notes

Section N: no additional notes

Section O: for new DER site, Distribution Operating Map (DOM) is required by GSHi in addition to Site Plan

Section P: When there is an upstream LDC, an additional **fee** will be required for costs associated with this LDC's CIA.

Section Q: no additional notes

Section R: no additional notes

Section S: - For question: "What is the barcode of the nearest pole serving the project location?", this is only applicable if you choose "No" to question: "Is there an existing GSHi account at the project location?" in Section D

- For question: "GSHi Account Number (if transformer is owned by GSHi)", this is only applicable if you answer "GSHi" to question: "Transformer Ownership" in Section L.



▶ APPENDIX A - FIGURES & DIAGRAMS

Figure A1: Where There is No New GSHi Owned Line Expansion

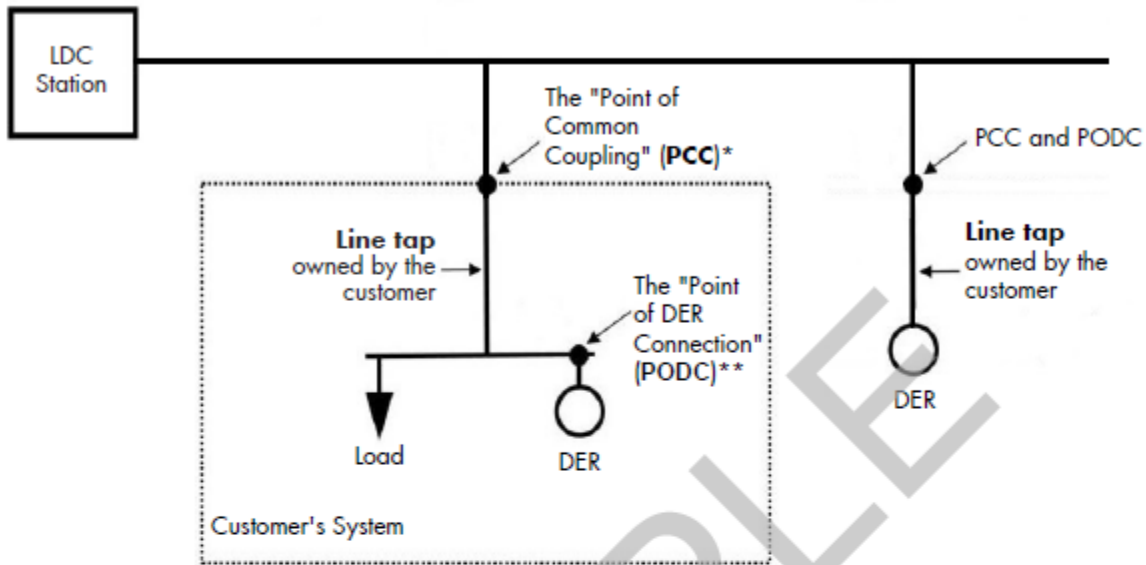

*PCC: the point where the customer facility connects to the LDC owned system

**PODC: the point where the DER unit(s)'s interconnection system connects the DER unit(s) to the DER facility.

Figure A2: Where There is a New GSHi Owned Line Expansion

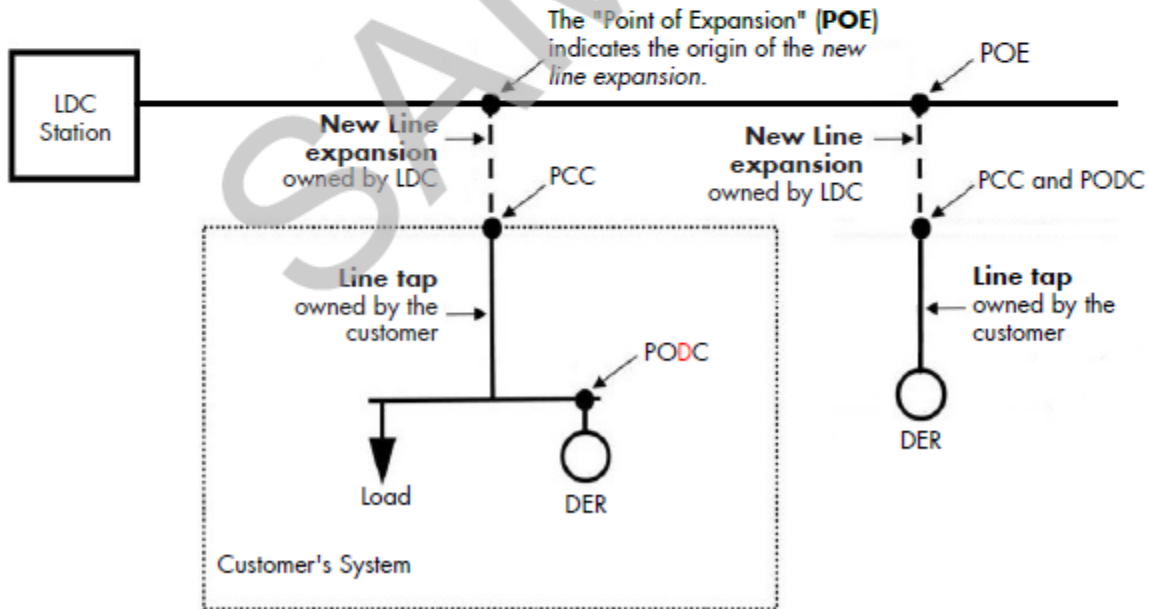



▶ APPENDIX B - MINIMUM CONTROL STRATEGY INFORMATION FOR ENERGY STORAGE FACILITIES OR OTHER TECHNOLOGIES

Figure B1: Peak Shaving

Peak Shaving			
Description of Control Strategy			
When Operating as a Load			
Switch In Time	Switch Out Time	Load kW (peak)	Load kVAR (peak, leading/lagging)
When Operating as a Generator			
Switch In Time	Switch Out Time	Generation kW (peak)	Generation kVAR (peak, leading/lagging)

Figure B2: Dynamic VAR Support

Dynamic VAR Support			
Description of Control Strategy			
Switch In Condition	Switch Out Condition	Generation kW (peak)	Generation kVAR (peak, leading/lagging)

Figure B3: Frequency Support

Frequency Support			
Description of Control Strategy			
Switch In Condition	Switch Out Condition	Generation kW (peak)	Generation kVAR (peak, leading/lagging)

Figure B4: Other Control Strategies

Other	
Description of Control Strategy and Relevant Operating Parameters	



▶ APPENDIX C - LOAD DISPLACEMENT FIGURES

Figure C1: Example Schedule With Minimum Information Required for Load Displacement Projects

	Load of Facility (kW)	Load of Facility (kVAR, lead or lag)	Generation Output (kW)	Generation Output (kVAR, lead or lag)
Minimum Load				
Maximum Load				

SAMPLE

Sample Protection Philosophy for Distributed Energy Resource Proponents Applying for Connection

This document is a summary of a sample protection philosophy for non-exporting, inverter-based (NE/I) connections including storage, solar, and wind. The OEB intends it as a guide for applicants regarding the kinds of protections, and particularly the categories of protections, that distributors will require for connection.

This is one example of a protection philosophy that would meet the requirements for a complete protection philosophy for the purpose of a CIA application¹. Other philosophies may also meet the standards. It provides guidance to a distributed energy resource (DER) proponent on good utility practice as it relates to protection requirements of non-exporting, inverter-based (NE/I) DERs. To form a protection scheme, all the elements for each category within any given protection philosophy are requirements.

This document is not an approval for connection. This information should help applicants file better and more complete applications for connection. An applicant will need to submit detailed protection settings after the utility has completed the impact assessment of the submitted connection application.

The standards and certification testing referenced in this document should be read as referring to the current versions of these standards at time of reading.

Sample Protection Philosophy for Non-exporting inverter-based Sources

Project Name: BEHIND THE METER EXA:

Project ID#: 12,345.

Project Type: Load Displacement

Capacity: 3,000 kW/3,000 VA

Connection feeder (optional): M1 at Example TS

In compliance with the technical interconnection requirements of the local distribution company for which this project will interconnect, the protection system of the connection will be designed to:

- Detect internal faults with the generator facility, downstream of the Point of Common Coupling (PCC), and automatically disconnect the NE/I source
- Detect external faults on the utility feeder and automatically disconnect the NE/I source
- Detect islanding conditions and disconnect the NE/I source
- Detect export of power from the NE/I source to the utility feeder and automatically disconnect the NE/I source

¹The contents of this document, although intended as guidance, conform to the interconnection and approval requirements prevalent at the time of its issuance. At all times, the current versions of relevant codes and standards govern.

Internal Faults Within the Generator Facility

The following protections are in place to protect against internal faults resulting from the NE/I source:

- **Multi-Function Relay**-At the PCC, a multi-function relay will be installed to monitor internal faults resulting from the NE/I source. The 52 Trip Breaker will trip if it detects the following:
 - 25 - Synchronization Check
 - 27 - Undervoltage
 - 59 - Overvoltage
 - 810/U - Under and Over Frequency
 - ID -Active Anti-Islanding
- **Inverter Breakers** - Each inverter is equipped with an AC breaker at the output of the inverter providing additional overcurrent protection
- **Facility Overcurrent Protection** -All circuits within the facility are protected from both phase-to-phase and phase-to-ground faults by appropriate overcurrent protection devices. Fuses are sized to clear under fault conditions within the generator facility

External Phase and Ground Faults in the Distribution System

The following protections are in place to protect against external faults resulting from the utility feeder:

- **Multi-Function Relay** - At the main utility service, prior to the first facility load, a multi-function relay will be installed to monitor faults from the utility feeder. The 52 Trip Breaker at the NE/I source PCC will trip under the following faults:
 - 27 - Undervoltage
 - 32 - Reverse Power
 - 50/51- Overcurrent
 - 59 - Overvoltage
 - 810/U - Under and Over Frequency
 - 67 - Directional
- **Inverter Protection:** The inverters proposed for this project are certified to UL 1741, IEC 62109-1, IEC 62109-2, CSA C22.2 107.1-01 standards² and will behave accordingly.

Anti-Islanding

- The Energy Resource Facility will operate in a grid following mode and will not operate islanded.
- **Anti-Islanding Inverters** -The NE/I source inverters contain both passive and

² AH references to standards or testing certifications should be read as the most current version.

active anti-islanding protection as required by IEEE 1547 and UL1741 SA. If the utility normal power supply is interrupted, the inverters detect the loss of power and disconnect.

Reverse Power

- **Reverse Power Protection** - In addition to the multi-function relay at the utility supply monitoring reverse power (32R), the load is continually monitored to ensure the NE/I source discharge is below the consumption of the facility. This additionally protects against power injection to the utility grid.

Directional Overcurrent

- **Directional overcurrent protection** - Directional overcurrent relays are normally used on incoming line circuit breakers on buses which have two or more sources. They are connected to trip an incoming line breaker for fault current flow back into the source, so that a fault on one source is not fed by the other sources.

Special Comment Regarding Inverter Based Generation

The inverters specified for this project have a limited fault current contribution

- Because inverters are current-limited devices, unlike rotating generators, the fault current is very close to the maximum output current, limiting the fault current in the system to 120% -140% of FLA.

Breaker Failure Scheme (Facilities with an aggregate output > 500kW)

In the event that 52-A fails to open when intertie protection relay calls for a trip, 52-B will instantaneously trip and lock out.

Reconnection

Manual reconnection: There is no automatic reconnection scheme at this facility. A manual reconnection will only be executed when given permission by the respective controlling authority.

Open Phase Protection

Open phase protection will be provided by 46 and/or 47 element(s) in the intertie protection relay to ensure the BESS maintains a balanced 3-phase output and detects loss of voltage in one or more phases and will trip the entire generating facility upon detection of such.

Communications and Transfer Trip/DGEO

Summarize communication systems and transfer trip/DGEO timing.

Table 1: Protection Summary Matrix

Description	IEEE Device	Internal Faults	External Faults	Anti-Islanding	Reverse Power	Trips 52-A	Trips 52-B	Disables Inverters
Over-Voltage	59	X	X	X		X		X
Under-Voltage	27	X	X	X		X		X
Over-Frequency	810	X	X	X		X		X
Under-Frequency	81U	X	X	X		X		X
Instantaneous Over-Current Phase	50	X	X			X		X
Timed Over-Current Phase	51	X	X			X		X
Reverse Power	32R			X	X	X	X	
Breaker Fail	50BF							
Active Anti-Islanding	IEEE 1547			X				X

Table 2: Protection Elements

Protection Element Function	Device#	Feeder/Protection Relay/Shunt Trip	IEEE 1741 SA Inverter
Over-Voltage	59	X	y
Under-Voltage	27	X	y
Over-Frequency	810	X	y
Under-Frequency	81U	X	y
Synchronization Check	25	X	y
Reverse Power	32R	X	
Overcurrent	50/51	X	y
Directional	67	X	
Active Anti-islanding	ID		X

X= Primary Y = Secondary